



TAP Plastics • tapplastics.com

## PRODUCT BULLETIN 2

### Cementing, Scratch-Removal and Care



## Acrylic Cement

### Instructions for Cementing Methods • Capillary • Soak • Laminating

## Scratch Removal Care of Sheets



TAP Acrylic Cement is for industrial use only

**TAP Acrylic Cement** is an all-purpose, solvent-type cement compounded especially for use on clear and colored acrylic sheets, Acrylite®, Plexiglas®, Lucite®, etc. It is generally used for edge gluing and softens the surface of the plastic, literally welding the two surfaces together. For best cementing results use a **TAP Hypo-Applicator**.

### General Working Tips

To avoid scratches, leave protective wrapper (masking material) in place while doing the finishing work such as cutting, drilling, and sanding.

**Note:** Wrapper must be removed prior to gluing or heat forming.

Keep wrapped acrylic sheet in a cool, dry place, protected from sunlight for long term storage.

Exposure to direct sunlight may make wrapper difficult or impossible to remove. Use **CleanUp Solvent 22** (a fast drying solvent, sold at TAP stores) to remove stubborn masking, grease, tar, stickers, and decals.

Proper tools are essential. Use a fine-tooth saw blade (with little or no set to the teeth), drill bits, and strip heaters that are made specifically for acrylic. These special tools are available from your local TAP store.

### TAP Hypo-Applicator

Fill the hypo-bottle no more than half way. Hold the bottle upright and squeeze slowly to expel air. Release pressure slowly while moving the hypo-applicator into position for gluing. This slow release creates a slight vacuum and lessens the possibility of dripping glue on the surface of the acrylic. When the hypo-applicator is in place, squeeze bottle gently and pull needle backwards along joint to be glued.

**Caution:** Do not push needle along joint as it plugs very easily.

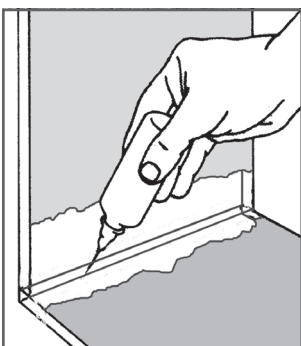

### Capillary Method

The joints or surfaces to be cemented must fit together snugly. Acrylic Cement will not fill gaps caused by uneven edges. The pieces must be supported in place until the cement sets. (Ask us how to use a gluing jig.) Where the two pieces join, the cement should be applied with a TAP Hypo-Applicator.

The cement will flow into the joint through capillary action. The union will 'set' quickly, firm enough to proceed with your work, and will reach high strength in 24-48 hours. Edges should not be flamed or polished prior to gluing, this could result in the edges crazing.

### Soak Method

Use the SOAK method for exceptionally strong and watertight joints or when using thick material. Dip the edge of one of the two pieces to be glued in a container with Acrylic Cement for one to three minutes. The container should be metal or glass—not plastic. Use pins to support the piece in the container. The plastic softens and provides an air-free cushion when the two pieces are joined together. (Do not allow Acrylic Cement to contact the face of the sheet.) The result is an ideal bond that becomes as strong as the sheet itself. It takes up to twenty-four hours to cure the joint.

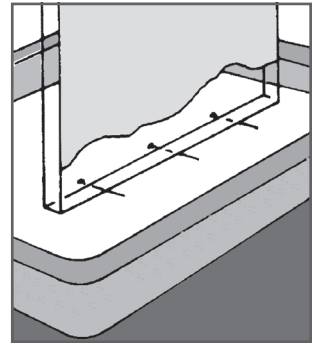

Use mild pressure and jigs to hold the plastic in position until the material sets.

### Laminating Method

Bubble-free laminations are difficult but possible and generally require experimentation.

- Cut pieces oversized, so that the laminated piece can be trimmed (after curing) to a bubble-free edge.
- Pour an excessive amount of Acrylic Cement on the face of the piece (or middle, up to 6" x 6") and slowly match surfaces, allowing the excess of squeezed-out of cement to carry off bubbles. Bring surfaces together as if closing up a "V" (see illustration).
- Protect the top acrylic face from excess cement and leave masking paper on the bottom sheet. Elevate sheets above the work surface to avoid cement contact with acrylic face.
- Allow to cure overnight before cutting or machining edges.

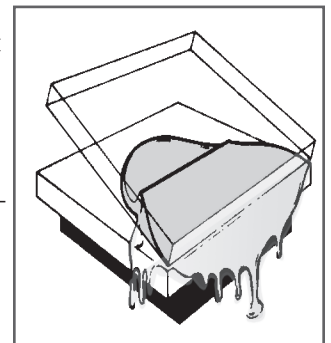

## Other Cementing Options

- For thick pieces or when working in a warm environment, Weld-On 4 Acrylic Cement offers a longer working time.
- For even surfaces, or where there is little contact between the pieces (i.e., gluing a sphere to a flat sheet), use Weld-On 16 Thickened Acrylic Cement.

## Cementing Tips

- If cement is accidentally spilled on the plastic, allow to dry through evaporation. Do not wipe off. Wiping will further mar the surface.
- Do not cement edges that have been polished; crazing will result.
- Do not rush the dry time.
- Cement small pieces of scrap to get the feel of the operation.
- High humidity may cause blushing (whitening) of glue joint.
- Use appropriate safety precautions whenever working with chemicals.

## Acrylic Scratch Removal

**Hairline Scratches on Acrylic** • Remove hairline scratches either with the **Novus Plastic Polishing System** or, follow any of the procedures for removing scuffs and minor scratches explained in the following paragraph.

TAP stocks **Wet or Dry Ultra-Fine Sandpaper**, which ranges in grits from 800 to 2000. Sand acrylic piece with Ultra-Fine Sandpaper and water until scratch disappears. Use the 2000 grit abrasive paper to create a uniform dull finish, then buff to its original luster with **Buffing Compound**.

The **Ultra-Fine Sandpapers** we carry were originally developed to remove defects from computer microchips. Their precise uniform grit particles eliminate sandpaper scratches and also the need for coarse buffing compounds. Ultra-Fine's uniform grit also extends the life of sandpaper.

**Note:** Use caution with motorcycle windshields. Most have a coating that prevents scratch repair. TEST FIRST!

## Dry Masking Adhesive or Paint Removal

Use **CleanUp Solvent 22** (a fast drying solvent, sold at TAP stores) to remove aged masking tape adhesive, grease, crayon, and other marks.

Follow instructions on label and test Safety Solvent 22 on a piece of acrylic before applying to problem area. Rinse acrylic with mild soap and water. Crazing can result if used on flame-polished edges and heat formed pieces.

## Caring For Acrylic Sheets

Remove dust from acrylic by wiping gently with **Brilliance®** or **Novus Plastic Polish 1** and a soft cloth, chamois, or **Lint-Free Wipes**. Never use a paper towel! Do not use cleaners containing abrasives, solvents, alcohol, or ammonia. Before using plastic cleaner, remove excess dust and grit with a wet towel or spray of water. A periodic cleaning with **Brilliance®** protects acrylic surfaces.

TAP carries several polishes and the proper **Lint-Free Wipes** and **MicroFiber Cleaning Cloth** to clean and maintain plastics.

**Note:** Various methods of manufacturing acrylic sheets result in slightly different gluing techniques. Your TAP sales person will be happy to give you small acrylic pieces for practicing gluing techniques.

Check our website and the video  
How to glue Acrylic at: [tapplastics.com](http://tapplastics.com)

*Because we have no control over working conditions or methods, products should be tested to establish suitability for your individual application. Our liability is limited to the price of the product.*

## Cautions • Acrylic Cement

Flammable Vapor! Harmful or fatal if swallowed. Contains Methylene Chloride and Trichloroethylene. Use with adequate ventilation. For contact with skin or eyes, flush with water. For eyes, contact doctor.

**KEEP AWAY FROM CHILDREN.**

**WARNING:** Use of this product will expose you to chemicals known to the State of California to cause cancer.

## TAP Plastics

<input type="checkbox"/> Bellevue WA	12021 NE Northup Way	425 861-0940
<input type="checkbox"/> El Cerrito CA	10760 San Pablo Avenue	510 778-9057
<input type="checkbox"/> Fremont CA	5160 Mowry Avenue	510 796-3550
<input type="checkbox"/> Lynnwood WA	4232 196th St. SW	425 977-4440
<input type="checkbox"/> Mountain View CA	312 Castro Street	650 962-8430
<input type="checkbox"/> Pleasant Hill CA	1478 Contra Costa Blvd	925 798-0420
<input type="checkbox"/> Pleasanton CA	6010-C Johnson Drive	925 460-8214
<input type="checkbox"/> Portland OR	2842 NE Sandy Blvd	503 230-0770
<input type="checkbox"/> Sacramento CA	4538 Auburn Blvd	916 481-7584
<input type="checkbox"/> Sacramento CA	4506 Florin Road	916 429-9551
<input type="checkbox"/> San Francisco CA	154 S. Van Ness Ave	415 864-7360
<input type="checkbox"/> San Jose CA	1212 The Alameda	408 292-8685
<input type="checkbox"/> San Leandro CA	3011 Alvarado Street	510 357-3755
<input type="checkbox"/> San Mateo CA	606 South B Street	650 344-7127
<input type="checkbox"/> San Rafael CA	900 Andersen Drive	415 454-6393
<input type="checkbox"/> Santa Rosa CA	2770 B Santa Rosa Ave	707 544-5772
<input type="checkbox"/> Seattle WA	710 9th Avenue North	206 389-5900
<input type="checkbox"/> Stockton CA	1859 Pacific Avenue	209 937-9300
<input type="checkbox"/> Tigard OR	15957 SW 72nd Avenue	503 620-4960

Printed on recycled paper.  
Revised January 2018



Corporate Office • San Leandro CA • (510) 895-8249

the fantastic plastic place

TAP Plastics • the fantastic plastic place  
Visit or shop online: [tapplastics.com](http://tapplastics.com)