

Plastic Sheets Care and Cementing

2

Acrylic Scratch Removal

Hairline Scratches on Acrylic • Remove hairline scratches either with the **Novus Plastic Polishing System** or, follow any of the procedures for removing scuffs and minor scratches explained in the following paragraph.

Scuffs, Minor Scratches, and Deep Scratches • Remove scuffs, minor (hairline) scratches, and very deep scratches from acrylic plastic furniture, displays, showcases, machine guards, and windows with **TAP Scratch Removal Kit**. It is suitable for most hard plastics. The kit contains everything you need:

- 5 Lint-Free WypAll®s (12" x 14")
- 1 bottle of Heavy-Duty Buffing Compound
- 1 bottle Professional Plastic Polish
- 1 piece Special Grit Wet-Or-Dry Sandpaper
- 1 bottle Anti-Static Solution

TAP stocks **Mequiar's Wet or Dry Ultra-Fine Sandpaper**, which ranges in grits from 800 to 2000. Sand acrylic piece with Ultra-Fine Sandpaper and water until scratch disappears. Use the 2000 grit abrasive paper to create a uniform dull finish, then buff to its original luster with **Buffing Compound**.

The **Ultra-Fine Sandpapers** we carry were originally developed to remove defects from computer microchips. Their precise uniform grit particles eliminate sandpaper scratches and also the need for coarse buffing compounds. Ultra-Fine's uniform grit also extends the life of sandpaper.

Note: Use caution with motorcycle windshields. Most have a coating that prevents scratch repair. TEST FIRST!

Dry Masking Adhesive or Paint Removal

Use **CleanUp Solvent 22** (a fast drying solvent, sold at TAP stores) to remove aged masking tape adhesive, grease, crayon, and other marks.

Follow instructions on label and test Safety Solvent 22 on a piece of acrylic before applying to problem area. Rinse acrylic with mild soap and water. Crazying can result if used on flame-polished edges and heat formed pieces.

Caring For Acrylic Sheets

Remove dust from acrylic by wiping gently with **Brilliance®** or **Novus Plastic Polish 1** and a soft cloth, chamois, or **WypAll®s** (the lint-free cloth). Never use a paper towel! Do not use cleaners containing abrasives, solvents, alcohol, or ammonia. Before using plastic cleaner, remove excess dust and grit with a wet towel or spray of water. A periodic cleaning with **Brilliance®** protects acrylic surfaces.

TAP carries several polishes and the proper lint-free cloth, **WypAll®s**, to clean and maintain plastics.

Because we have no control over working conditions or methods, products should be tested to establish suitability for your individual application. Our liability is limited to the price of the product.

Note: Various methods of manufacturing acrylic sheets result in slightly different gluing techniques. Your TAP sales person will be happy to give you small acrylic pieces for practicing gluing techniques.

Check our website: tapplastics.com.

the fantastic
plastic place

TAP Plastics

<input type="checkbox"/> Bellevue WA	12021 NE Northup Wy	425 861-0940
<input type="checkbox"/> Dublin CA	7176 Regional St	925 828-7744
<input type="checkbox"/> El Cerrito CA	10760 San Pablo Av	510 525-3508
<input type="checkbox"/> Fremont CA	5160 Mowry Av	510 796-3550
<input type="checkbox"/> Mountain View CA	312 Castro St	650 962-8430
<input type="checkbox"/> Pleasant Hill CA	1478 Contra Costa Bl	925 798-0420
<input type="checkbox"/> Portland OR	2842 NE Sandy Bl	503 230-0770
<input type="checkbox"/> Sacramento CA	4538 Auburn Bl	916 481-7584
<input type="checkbox"/> Sacramento CA	4506 Florin Rd	916 429-9551
<input type="checkbox"/> San Francisco CA	154 S. Van Ness Av	415 864-7360
<input type="checkbox"/> San Jose CA	1212 The Alameda	408 292-8685
<input type="checkbox"/> San Jose CA	1008 Blossom Hill Rd	408 265-6400
<input type="checkbox"/> San Leandro CA	3011 Alvarado St	510 357-3755
<input type="checkbox"/> San Mateo CA	606 South B St	650 344-7127
<input type="checkbox"/> San Rafael CA	900 Andersen Dr	415 454-6393
<input type="checkbox"/> Santa Rosa CA	2770 Santa Rosa Av	707 544-5772
<input type="checkbox"/> Seattle WA	710 9th Avenue North	206 389-5900
<input type="checkbox"/> Stockton CA	5757 Pacific Avenue	209 957-2036
<input type="checkbox"/> Tigard OR	15230 SW Sequoia Pkwy	503 620-4960

Corporate Office • Dublin CA • 925 829-4889

Printed on recycled paper.



April 2004

**Acrylic
Cement**
**Laminating
Cement**

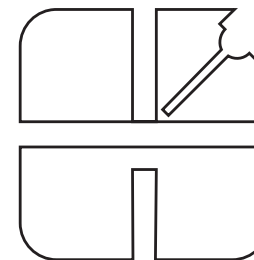

**Scratch
Removal**
**Care of
Sheets**

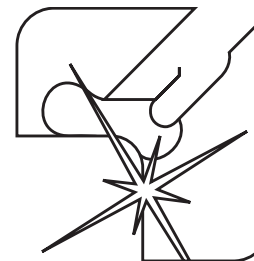

TAP Plastics • the fantastic plastic place
Visit or shop online: tapplastics.com

Instructions for Cementing Methods • Capillary • Soak • Laminating

TAP Acrylic Cement is an all-purpose, solvent-type cement compounded especially for use on clear and colored acrylic sheets, Acrylite®, Plexiglas®, Lucite®, etc. It is generally used for edge gluing and softens the surface of the plastic, literally welding the two surfaces together. For best cementing results use a **TAP Hypo-Applicator**.

General Working Tips

To avoid scratches, leave protective wrapper (masking material) in place while doing the finishing work such as cutting, drilling, and sanding.

Note: *Wrapper must be removed prior to gluing or heat forming.*

Keep wrapped acrylic sheet in a cool, dry place, protected from sunlight for long term storage.

Exposure to direct sunlight may make wrapper difficult or impossible to remove. Use **CleanUp Solvent 22** (a fast drying solvent, sold at TAP stores) to remove stubborn masking, grease, tar, stickers, and decals.

Proper tools are essential. Use a fine-tooth saw blade (with little or no set to the teeth), drill bits, and strip heaters that are made specifically for acrylic. These special tools are available from your local TAP store.

TAP Hypo-Applicator

Fill the *hypo-bottle* no more than half way. Hold the bottle upright and squeeze slowly to expel air. Release pressure slowly while moving the *hypo-applicator* into position for gluing. This slow release creates a slight vacuum and lessens the possibility of dripping glue on the surface of the acrylic. When the *hypo-applicator* is in place, squeeze bottle gently and pull needle backwards along joint to be glued.

Caution: Do not push needle along joint as it plugs very easily.

Capillary Method

The joints or surfaces to be cemented must fit together snugly. Acrylic Cement will not fill gaps caused by uneven edges. The pieces must be supported in place until the cement sets. (Ask us how to use a gluing jig.) Where the two pieces join, the cement

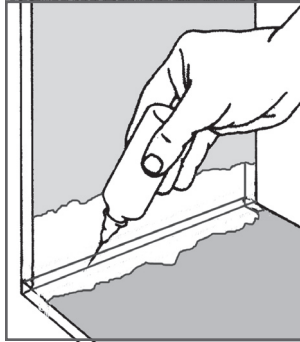

should be applied with a **TAP Hypo-Applicator**. The cement will flow into the joint through capillary action. The union will 'set' in about sixty minutes, firm enough to proceed with your work, however it will not fully cure to a maximum strength for eight hours. Edges should not be flamed or polished prior to gluing, this could result in the edges crazing.

Soak Method

Use the SOAK method for exceptionally strong and water-tight joints or when using thick material. Dip the **edge of one** of the two pieces to be glued in a container with **Acrylic Cement** for one to three minutes. The container should be metal or glass—not plastic. Use pins to support the piece in the container. The plastic softens and provides an air-free cushion when the two pieces are joined together. (Do not allow Acrylic Cement to contact the face of the sheet.) The result is an ideal bond that becomes as strong as the sheet itself. It takes up to twenty-four hours to cure the joint.

Use mild pressure and jigs to hold the plastic in position until the material sets.

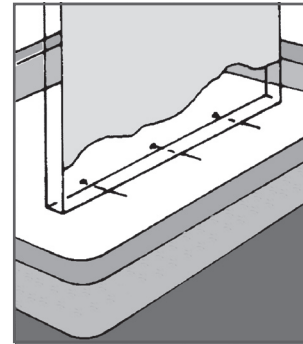

Cautions • Acrylic Cement

Flammable Vapor! Harmful or fatal if swallowed. Contains Methylene Chloride and Propylene Glycol Monomethyl Ether. Use with adequate ventilation. For contact with skin or eyes, flush with water. For eyes, contact doctor.

KEEP AWAY FROM CHILDREN.

WARNING: Use of this product will expose you to chemicals known to the State of California to cause cancer.

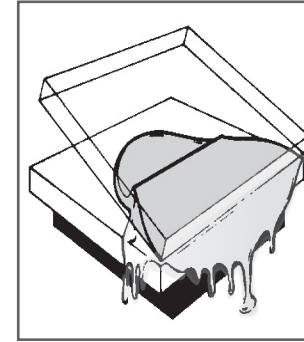

Laminating Method

Bubble-free laminations are difficult but possible and generally require experimentation.

- Cut pieces oversized, so that the laminated piece can be trimmed (after curing) to a bubble-free edge.

- Pour an excessive amount of Acrylic Cement on the face of the piece (or middle, up to 6" x 6") and slowly match surfaces, allowing the excess of *squeezed-out* of cement to carry off bubbles. Bring surfaces together as if closing up a "V" (see illustration).
- Protect the top acrylic face from excess cement and leave masking paper on the bottom sheet. Elevate sheets above the work surface to avoid cement contact with acrylic face.
- Allow to cure overnight before cutting or machining edges.

Cementing Tips

- If cement is accidentally spilled on the plastic, allow to dry through evaporation. Do not wipe off. Wiping will further mar the surface.
- Do not cement edges that have been polished; crazing will result.
- Do not rush the dry time.
- Cement small pieces of scrap to get the feel of the operation.
- High humidity may cause blushing (whitening) of glue joint.
- Use appropriate safety precautions whenever working with chemicals.