

# castin'craft BY CASEY

## IDEA BOOK

KEY TO MY HEART  
NOTE HOLDER

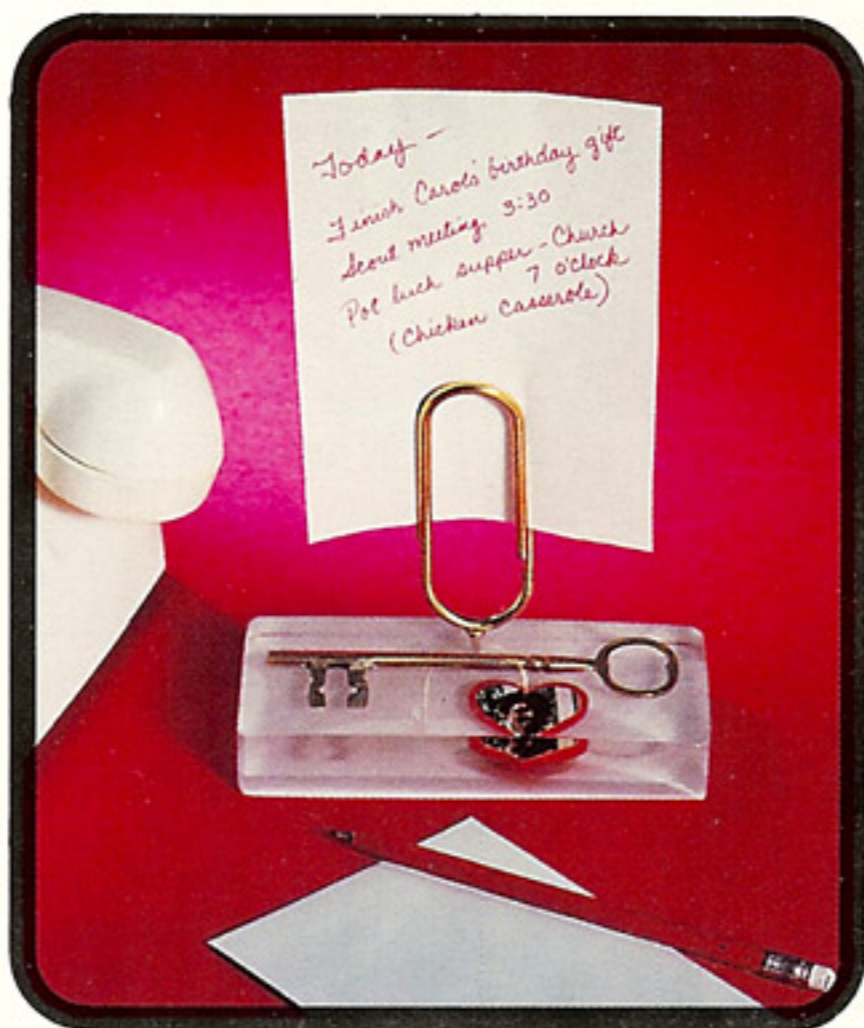

FROZEN  
OCEAN



BUTTERFLY  
WIND CHIME



EMBROIDERY  
PAPER WEIGHT



CREEPY-CRAWLER  
COOLER

**fun,  
step-by-step  
resin casting  
projects!**

## FOREWORD

Although I've been involved with a wide variety of crafts over the years — first, as a small manufacturer of handcrafted gifts, and more recently as a craft counselor and manager for Better Homes & Gardens Craft Creations — I'd never worked with casting resin! With a little experimenting, I quickly turned into a resin casting fan! When I discovered there were no craft books currently in print on the subject, I decided to put together what I was learning in the form of a basic instruction and project book. The **CASTIN' CRAFT IDEA BOOK** is designed to be used by beginners as well as a 'refresher' for those of you who turned out grape clusters and clackers back in the 70's.

The practical, pretty and fun projects shown in this book have all been made using simple polypropylene plastic molds which are available in eight sizes. Ideal for resincraft projects, these 'poly' molds are inexpensive, reuseable, versatile . . . and very easy to use.

Before making your first project, read thoroughly the sections on "Do's & Don'ts", "Basics", and "Steps to Perfect Resin Casting".

By understanding and following some basic guidelines, you should have excellent results with your first project. I know you'll enjoy personalizing the projects shown . . . for gift giving or your own use. Once you've mastered the basic techniques of resin casting, you'll be ready to create new projects using the poly molds shown here, some of the other mold types I tell you about in 'Basics', or perhaps even making your own molds from liquid latex.

I'm already working on projects for a new resin-craft book. If you have ideas you'd like to share and possibly see included, just write to me at the address below.

Happy Resin Crafting

Casey Carlton

## LIABILITY

The information in this instruction book is presented in good faith, but no warranty is given nor results guaranteed, nor is freedom from any patent to be inferred. As we have no control over physical conditions surrounding the application of information herein contained, E.T.I. disclaims any liability.

All rights reserved. No part of this book may be reproduced in any form, without permission in writing from E.T.I., Fields Landing, CA 95537.

© 1982 E.T.I., Fields Landing, CA 95537



## DO's & DON'Ts FOR RESIN CRAFTING

- DO keep resin, catalyst, dyes and pigments out of the reach of children.
- DO follow the directions and cautions on resin crafting product labels.
- DO work in a well-ventilated 65° to 75° F. room.
- DO keep acetone or rubbing alcohol handy for cleanup of liquid resin.
- DO use disposable gloves (and/or tweezers) when doing a project which requires dipping embeddings into the catalyzed resin.
- DO use a clean mixing container and stir stick for each new batch of resin you mix.
- DO use scratch-free clean and dry molds.
- DO add the proper amount of catalyst and stir thoroughly with the casting resin.
- DO experiment with small castings before attempting larger or more difficult projects.
- DON'T pour catalyzed resin back into the resin can.
- DON'T work with casting resin around food as it may affect its taste.
- DON'T pour excess resin in sink . . . it will clog the drain!
- DON'T disturb a casting until it has thoroughly cured.

FOREWORD .....	OPPOSITE
DO'S & DON'TS OF RESIN CASTING .....	OPPOSITE
BASICS OF RESIN CASTING WITH POLY MOLDS .....	PAGE 1
STEPS TO PERFECT RESIN CASTING WITH POLY MOLDS .....	PAGE 2
PROJECTS	
FROZEN OCEAN .....	PAGE 5
KEY TO MY HEART NOTE HOLDER .....	PAGE 6
EMBROIDERY PAPERWEIGHT .....	PAGE 7
KEY I.D. ....	PAGE 8
CREEPY CRAWLER COOLER .....	PAGE 9
NIGHTY-NIGHT-LIGHT .....	PAGE 10
FROSTED ORNAMENTS .....	PAGE 11
"TIMELESS" PEN HOLDER .....	PAGE 12
"WORLD'S GREATEST" TROPHY .....	PAGE 13
EGG TIMER RECIPE HOLDER .....	PAGE 14
BUTTERFLY WIND CHIME .....	PAGE 15
GLOSSARY OF RESIN CASTING TERMS .....	BACK
CASTIN' CRAFT PRODUCTS .....	BACK

# castin' craft IDEA BOOK

## CONTENTS

## BASICS OF RESIN CASTING

Resin casting is an exciting and fun craft that allows you to embed or encase almost any object in crystal-clear plastic. The basic materials needed to get started in resin crafting are easy to find and relatively inexpensive.

You'll need: Casting resin and catalyst

Disposable graduated paper mixing cups

Wooden stir sticks

A mold

Objects you wish to embed

Color dyes and pigments are optional and can be used to create a variety of special effects and backgrounds. Resin crafting supplies are available at hobby, craft and plastics supply stores.

Understanding the basics of how casting resin can be changed from a liquid to a solid will enable you to successfully create a wide variety of both practical and fanciful projects that will last indefinitely!

### CASTING RESIN

A polyester resin noted for its clarity and ability to be cast in mass. In its liquid form, casting resin has a consistency of corn syrup and a slight color ranging from straw to light aqua. During the hardening process the slight color bleaches out and the resin becomes crystal clear. The styrene odor of casting resin is less objectionable if you have good ventilation when pouring. Once cured, your cast pieces will have little if any odor. Casting resin should be stored at room temperature (72° F.), out of direct sunlight, and out of reach of children. If stored properly, shelf life is approximately nine to twelve months.

### CATALYST

Added to liquid casting resin, catalyst (hardener) produces a chemical reaction which generates heat, causing the resin to harden. The amount of heat generated depends upon four factors:

- Amount of catalyst used
- Thickness of the casting
- Air temperature and temperature of casting resin
- Amount of color pigment or dye (if used)

Increasing any of these factors alone or in combination changes the rate of curing or hardening. For example. . . .

- Increasing the amount of catalyst causes the resin to cure more quickly. Over-catalyzing, however, can cause excessive heat, fractures in the cast

piece, fading of embedments, or distortion of the mold. Under-catalyzing may produce a cast piece with a sticky or tacky surface.

- A thick casting cures more quickly than a thin casting.
- The higher the room temperature, the faster a casting will cure.
- Adding too much color will slow down or inhibit the cure.

During the curing process, the catalyzed resin goes through a series of stages from a liquid to a 'soft gel' in about 15 to 20 minutes, a 'firm gel' in 20 - 30 minutes and finally to a 'click-hard' (cured) stage in 1 to 24 hours. The length of this cycle will vary greatly depending on the four factors mentioned previously.

The period of time between the addition of the catalyst and the gel stage is called the 'working time' or 'pot life' of the resin. Generally this is about 15 to 20 minutes. Do not catalyze more resin than you can pour during the 'working time' since catalyzed resin cannot be poured once it has gelled. Do not pour catalyzed resin back into your casting resin can. Catalyst should be stored at room temperature, out of sunlight and out of reach of children. Shelf-life is indefinite as long as stored properly.

### EMBEDMENTS

Here are some suggested objects that can be suspended or encased in casting resin: **Crushed glass • Coins • Fabric\* • Flowers - dried or pressed • Glass jewels or marbles • Glitter • Insects or biological specimens • Jewelry findings • Leaves - dried or pressed • Mechanical parts, nuts bolts etc. • Metal-coins or engraved plates • Paper\* • Photographs\* • Rocks, pebbles, gravel • Seeds, peas, beans, pasta, spices • Sequins • Shells • Smaller resin castings • Stamps, paper money • Wood\***

\* Seal objects that have a tendency to 'wet out' or darken when a liquid is poured over them. Ultra-Seal™ vinyl resin glue/sealer or 4 parts white glue to 1 part water works well. Brushed on coats of glue or sealer should be allowed to dry completely before embedding the coated object in casting resin.

Any embedment must be dry, wax-free and grease-free for the resin to adhere well. Embedding plastic pieces requires experimentation as the heat generated during casting may cause some plastics to distort. For example. . . acrylic, polyethylene and polypropylene plastic pieces seem

to be more heat-resistant than those made of vinyl or styrene based plastic.

## COLORANT

Use only dyes and pigments designed for use with polyester casting resin. Dyes are generally transparent, allowing you to 'see through' the cast piece. Pigments are generally opaque, providing a solid color.

Colorants may be used to color an entire casting or can be used in the final layer to create a background. Keep in mind that colored resin in your mixing container will look much darker than when poured into a thinner area. As a general rule 2 to 3 drops of colorant per ounce of resin will produce the desired intensity of color.

## MOLDS

A variety of mold materials can be used for resin casting ...

- Oven-proof glass, such as Pyrex™
- Latex, natural rubber
- Flexible vinyl plastisol
- Metal, aluminum, stainless steel
- Silicone, R.T.V. rubber
- Ceramic
- Polypropylene and polyethylene
- Polyurethane elastomers

(Note: Some mold types require the use of a mold release to keep the casting from sticking to the mold.)

# STEPS TO PERFECT RESIN CASTING WITH 'POLY' MOLDS

## PREPARATION

- **Read all instructions before starting your project!** These include manufacturer's label cautions as well as project directions.
- Choose a well-ventilated area away from any food preparation, where a room temperature of 65° to 75° F. can be maintained.
- Cover a level working surface with Mylar™ plastic sheeting, several layers of wax paper secured over newspapers, or sheets of plastic wrap taped to your work surface. (Mylar™ is available at art and graphic supply stores and at plastic supply stores.)
- Gather *all* materials before starting your project.
- Keep acetone or rubbing alcohol handy for cleanup of liquid casting resin.

## MEASURE RESIN

- Determine the number of layers to be poured and the amount of resin required for your first layer. If the mold you are using does not state the number of ounces it contains, fill the mold with water and then pour into a measuring cup to determine the total amount of resin that will be needed.
- Allow plastic poly molds to air-dry to avoid scratches; non-plastic molds may be dried with a lint-free cloth or paper towel.
- Use a wax-free disposable paper measuring/mixing cup with ounce graduations for accurate measuring of resin.
- Do not use styrofoam or clear plastic cups as they will melt when contacted by catalyzed resin.
- Use a clean cup and stir stick for each batch of resin mixed.
- Pour the appropriate amount of casting resin into your disposable measuring/mixing cup.

## IMPORTANT!

### POLY MOLD CATALYST CHART

This chart is intended as an approximate guide only, and is expressed in drops of catalyst per ounce of resin. It is based on a room temperature of 70°-75°F. For warmer temperatures, decrease catalyst by a drop per ounce of resin; for cooler temperatures, increase the amount of catalyst by a drop per ounce of resin. It may be necessary to experiment to determine the correct amount of catalyst for your specific conditions.

\*Note: When using poly molds 1 thru 5, use the higher numbers of drops of catalyst recommended. When using their poly molds 6 thru 8, use the lower number of drops of catalyst recommended.

\*\*Note: If pouring more than five layers, keep in mind that each catalyzed layer adds to the build-up of the heat during the curing process. You'll need to experiment to determine the number of drops of catalyst for each layer that will allow a good, hard cure without fracturing around embedments.

#### SINGLE-LAYER POUR

Layer Depth	Drops of Catalyst Per Oz. of Resin
1/8"	12 - 15
1/4"	8
1/2"	6
3/4"	5
1" - 1-1/2"	4

#### MULTIPLE LAYER POUR\*

Layer	Drops of Catalyst Per Oz. of Resin
1st Layer	4-5
2nd Layer	3-4
3rd Layer	2-3
4th Layer	1-2
**5th Layer	1

- Use disposable wooden stir sticks or tongue depressors for mixing.

## ADD COLORANT (optional)

- Add just a little dye or pigment at a time until the desired shade is achieved. Generally, two or three drops of colorant per ounce of resin will provide the intensity desired. Too much colorant will inhibit the cure of the resin.
- Remember . . . the color will look darker in the cup than in the casting, due to the depth of the container. Stir well to blend.

## ADD CATALYST

- The size of the mold, the depth of the pour and your room temperature will determine the amount of catalyst used.
- Following the chart opposite or the resin manufacturer's label directions, add the appropriate amount of catalyst to the casting resin. It is very important to be exacting in this step to assure proper curing.

## MIX THOROUGHLY

Using a stir stick or tongue depressor, mix resin and catalyst *thoroughly* and *vigorously* for at least one minute. Scrape the sides and bottom of cup with your stir stick to insure proper mixing of resin and catalyst.

## POUR INTO MOLD

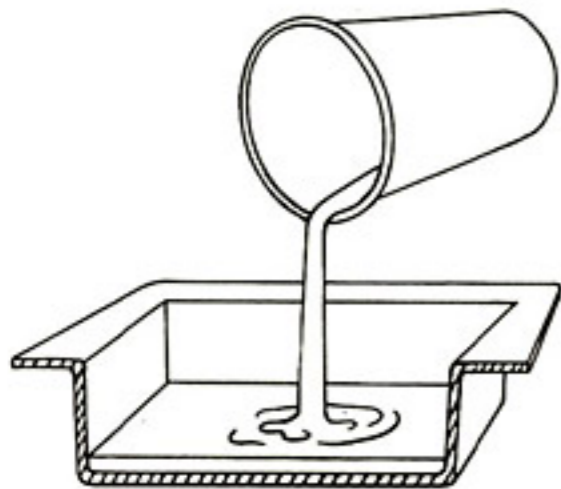

Figure 1

Make sure mold is clean, dry and level before pouring. Do not pick up or move the mold once you have poured the first layer. (See Fig. #1)

## ALLOW TO GEL

- Resin will gel (to consistency of set Jello™) in about 15 to 25 minutes. Test the surface with a stir stick. There must be sufficient firmness to support the weight of your embedments. If surface has not reached a firm gel, wait a few more minutes and test again with your stir stick.
- *Layers in a casting must not be allowed to fully cure or harden until the final layer has been poured.* A fully cured layer will shrink away from the sides of the mold, allowing an additional pour to run down the sides of the previous layers. If this should occur, it would necessitate a lengthy sanding and polishing job.

## PLACE YOUR EMBEDMENTS

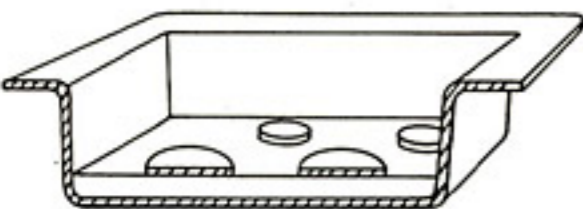

Figure 2

- REMEMBER . . . you are layering in reverse. The first layer you pour becomes the front of your cast piece.
- Put embedments in place face down on top of the gelled layer. (See Figure #2)

## TIPS TO PREVENT TRAPPING AIR BUBBLES

- When embedding items that may entrap air bubbles on their 'face', pour half of your next batch of catalyzed resin

into the mold before placing the embedments. Then, lower embedments *slowly* into the resin to expel air bubbles.

- For a dimensional object such as a dried flower, dip it into your next batch of catalyzed resin before placing face down onto the gelled surface.
- Gently press embedments with your stir stick to free trapped bubbles.

## POUR ADDITIONAL LAYERS

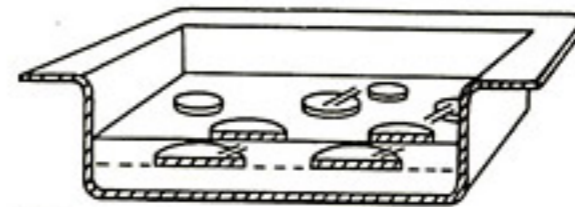

Figure 3

- Additional layers of embedments will give the appearance of greater depth and a dimensional 'floating' look.
- Referring to the Catalyst Chart, add layers, repeating the procedure previously outlined. Be sure to allow each layer to gel before adding embedments. (See Figure #3)

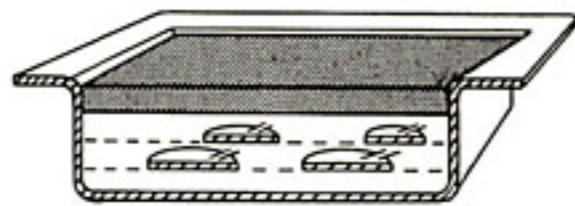

Figure 4

- For the final layer you may wish to create a background using colorants. Generally, 2-3 drops of dye or pigment per ounce of casting resin will produce the desired color without inhibiting the cure. Dye or pigment is added to the resin in addition to catalyst. Make sure the previous layer has firmly gelled before pouring the final color layer. Do not overfill your mold. (See Figure #4)

## SPECIAL NOTE

Also in combination with colorant you may use 6 to 8 drops of a surface curing agent per ounce of resin. Surface curing agent is used *in addition to catalyst* and resin to produce a tack-free surface. (When a surface curing agent is used without colorant, the appearance of the final layer will be slightly hazy rather than clear.)

## REMOVE CASTING FROM MOLD

- Tap the surface of your cast piece with a clean stir stick. When cured, it will 'click hard' without sticking when tapped. The edges of the cast will have shrunk away from the sides of the mold and all or part of the face of the mold.
- If surface tackiness remains, allow up to several days hardening time, checking periodically.
- Grasp the mold by the edges, invert over a clean piece of Mylar™ or plastic wrap and flex the mold as you would an ice cube tray. The cast, if properly catalyzed and hardened, should drop out of the mold easily.
- To minimize blemishes and fingerprints, do not handle your casting until it is absolutely dry.

## FINISH BACK OF CASTING

- It is normal for the final surface layer to have a slightly textured 'orange peel' appearance.
- To protect table tops and provide a more finished look, you may want to cut a piece of felt or sheet cork and glue it to the base of your cast piece. Epoxy glue or bond cement works well.
- To remove minor blemishes such as fingerprints, spray with several coats of Resin Craft Surface Coat spray, which is a clear acrylic sealer.

- If an absolutely smooth perfect finish is desired, sand any rough edges with #80 grit sandpaper to create a flat surface. Then 'wet-sand' with #240, #400, and #600 grit sandpapers. Polish out any minute scratches with a polishing compound such as jewelers' rouge or rubbing compound. Polishing can be extremely time consuming and can be avoided by using a color background and/or covering the back of your casting with felt.

## **CARE OF POLY PLASTIC MOLDS**

- Because they scratch easily, do not wipe or scrub the inside of a plastic mold. Swish mold in a mild detergent and hot water solution if dirty.
- Rinse mold with hot tap water, allow to air-dry, and store in a clean closed container.
- Cared for properly, poly plastic molds can be used over and over again.
- Once you have used a plastic mold for casting with resin, do not use it to serve or store food, as the taste of the resin may be picked up. 'Retired' pieces of Tupperware™ make excellent molds.

# **castin' craft PROJECTS**

## **INTRODUCTION TO PROJECT SECTION**

The practical pretty and fun projects shown in the next section are all made using simple polypropylene plastic molds which need no mold release. If you're a brand new resin crafter, start with one of the beginner projects. Make sure that children (at least 10 - 12 years old) working with resin crafts are well supervised and familiar with the cautions on product labels. By following the step-by-step instructions included with each project, you should have professional results on your first try. Soon you'll be thinking up your own designs—a sure sign you've caught the Castin'Craft bug!

## 4-LAYER CASTING (INTERMEDIATE)

Whether you collect the embedments yourself or purchase them from a shell shop, this dimensional project is a delightful way to enjoy treasures from the sea. Use your 'Frozen Ocean' with other castings as part of a shell and sea life collection, or use as a paperweight.

# FROZEN OCEAN



## MATERIALS NEEDED

- 1 MC-4 Poly Mold (2-1/8" x 3-1/4" x 1-1/8")
- 4 Oz. Polyester Casting Resin
- Catalyst
- 4 Graduated Paper Mixing Cups
- 4 Stir Sticks
- Small shells, coral, tiny starfish and sea horse for embedding
- Turquoise and Pearl Transparent Dyes for Polyester Casting Resin
- Acetone or Rubbing Alcohol for clean-up

## INSTRUCTIONS

### First Layer

- In paper mixing cup measure and mix thoroughly 1 ounce of resin and 5 drops of catalyst. Pour into mold.
- Allow to gel, about 20 to 25 minutes.

### Second Layer

- Place sea horse face down on gelled surface of first layer.
- In a clean mixing cup, measure and mix thoroughly 1 ounce of resin and 4 drops of catalyst.
- Pour second layer over sea horse and allow to gel 15 to 20 minutes.

### Third Layer

- Arrange shells, starfish and coral face down on a second layer of gelled resin.
- In a clean mixing cup, measure and mix thoroughly 1 ounce of resin and 3 drops of catalyst. Pour third layer and allow to firm gel about 20 minutes.

### Fourth Layer

- In a clean mixing cup, measure and mix thoroughly 1 ounce of resin, 2 drops of Pearl Dye, 1 drop of Turquoise Dye, and 2 drops of catalyst.
- Pour this final layer and allow your Frozen Ocean to harden completely.
- When cured (hardened), the edges of the casting will shrink away from sides of the mold. The surface will 'click-hard' when tapped with a stir stick. (This will take from 4 to 24 hours depending on your room temperature.)

## REMOVE CASTING FROM MOLD

- Invert mold, grasp edges, flex and allow the casting to gently drop onto a piece of Mylar™ or plastic wrap.
- Do not handle your casting until it is completely tack-free.

TIP: Some small shells and sea creatures will continue to make air bubbles which will be trapped in the finished piece. For example . . . a sea horse will sometimes appear to be blowing bubbles! If you prefer not to have any bubbles trapped in your finished piece, soak shells and sea creatures in catalyzed resin for 5 to 10 minutes before embedding. This process allows resin to soak into air pockets. Using tweezers, remove shells from the resin, place on gelled layer, and pour your next layer. Clean tweezers with acetone or rubbing alcohol immediately.

## 4-LAYER CASTING (INTERMEDIATE)

What a nice way to remember someone you care about! For this project I've embedded a giant brass key (found at a local discount import store) and a photo glued onto a red acrylic heart. The jumbo paper clip makes this project an eye-catching and practical desk accessory for use at home or at the office. You can personalize this note holder by embedding photos, ticket stubs, or other keepsakes.

# "KEY TO MY HEART" NOTE HOLDER

### MATERIALS NEEDED

- 1 1-1/2" x 1-1/2" x 1/8" Acrylic Plastic Heart with photo cut and glued onto the front. A peel-and-press heart sticker may be substituted
- 1 MC-8 Poly Mold (3" x 6" x 1-1/16")
- 9 Oz. Polyester Casting Resin
- Catalyst
- 4 Graduated Paper Mixing Cups
- 4 Stir Sticks
- Color Pigment for Polyester Casting Resin
- 1 5" long Brass Key
- Acetone or Rubbing Alcohol for clean-up
- Electric Drill with 1/8" drill bit
- 1 6" Jumbo Paper Clip with a screw tail. (Check hobby or stationery store. The one I used is manufactured by W. T. Rodgers Co., Madison, Wisc.)

Optional: Self-adhesive felt circles, available at variety or craft stores.

### INSTRUCTIONS

If using a peel-and-press heart sticker which is readily available at stationery stores...

- Mount the sticker on a piece of cardboard and trim.
- Glue photo to face of sticker and seal sticker front and cardboard back with ULTRA-SEAL™ white vinyl resin/glue, or four parts of white glue mixed with one part of water. Allow to dry thoroughly before embedding.
- This procedure will keep the sticker and photo from curling and 'wetting out' once it's been embedded in casting resin.

#### First Layer

- In paper mixing cup measure and mix thoroughly 3 ounces of casting resin and 12 drops of catalyst.
- Pour into level mold and allow to gel about 20 to 25 minutes.

#### Second Layer

- Place brass key onto gelled layer.
- In clean paper mixing cup measure and mix thoroughly 2 ounces of casting resin and 6 drops of catalyst.
- Pour over key and first gelled layer.
- Allow this layer to gel about 20 minutes.

#### Third Layer

- In a clean paper mixing cup measure and mix thoroughly 2 ounces of casting resin and 4 drops of catalyst.

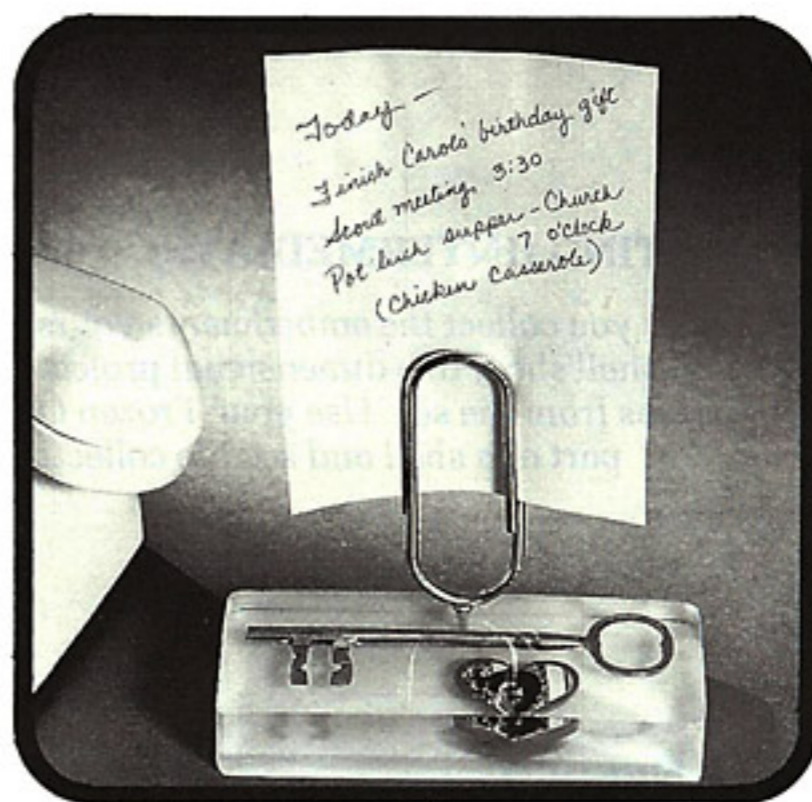

- Pour half of this mixture onto the second gelled layer.
- Carefully place heart with photo side down into the resin you've just poured. Gently press heart with stir stick to force out any trapped air bubbles.
- Pour remaining half of catalyzed resin into mold over the heart.
- Allow this layer to firm gel about 20 minutes.

#### Fourth Layer

- In a clean paper mixing cup measure and mix thoroughly 2 ounces of casting resin, 4 to 6 drops of color pigment, and 2 drops of catalyst.
- Pour over gelled surface. Do not overfill mold.
- Allow casting to completely cure or harden before removing from the mold (about 12 to 24 hours). When cured, the casting will shrink away from the sides of the mold. The surface will be 'click-hard' when tapped with a stir stick.

### REMOVE CAST FROM MOLD

- Invert mold, flex edges, and allow the casting to gently drop out onto a sheet of Mylar™ or plastic wrap.
- Do not handle casting until it is completely tack-free.

### FINISHING

- Using the 1/8" bit, drill a hole the length of the paper clip screw, 1/2" down from the front center of the cast piece.
- Screw the jumbo paper clip into the hole you've drilled.
- Press a self-adhesive felt circle to each corner of the back of the casting to protect furniture.



### 3-LAYER CASTING (INTERMEDIATE)

Preserve a work of love for someone special in the form of a dome paperweight. Due to the curved surface of the dome, the detail of counted cross stitch shown here is beautifully magnified! One tip for embedding fabric is to seal the mounted piece with a vinyl resin glue/sealer. This prevents the fabric from 'wetting out'. On rough textured pieces, such as needlepoint, you'll need two seal coats to prevent 'wet-out'.

## EMBROIDERY PAPERWEIGHT



### MATERIALS NEEDED

- 1 Completed Counted Cross-Stitch or Crewel Miniature (Maximum size of design should be 2" in diameter)
- 1 2<sup>5</sup>/<sub>8</sub>" diameter Cardboard Circle
- 1 1/2" Paint Brush (an 'acid tinning brush' works well)
- 1 4-oz. Jar ULTRA-SEAL™ white vinyl resin glue/sealer (or 4 parts' white glue mixed with 1 part water)
- 1 MC-5 Poly Mold (3" diameter x 1-3/8" dome)
- 4 Oz. Casting Resin
- Catalyst
- 3 Graduated Mixing Cups
- 3 Stir Sticks
- Color Pigment for Polyester Resin (choose a color that compliments your embroidered piece)
- Acetone or Rubbing Alcohol for clean-up
- Optional: 3" Circle of Felt
- Epoxy Glue or Bond Cement

### INSTRUCTIONS FOR MOUNTING FABRIC

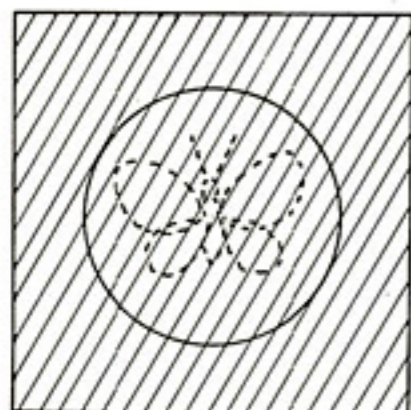

Figure 1

- Center cardboard circle on wrong side of embroidered fabric. Trace a guideline around outside of cardboard with a pencil. (See Figure #1)

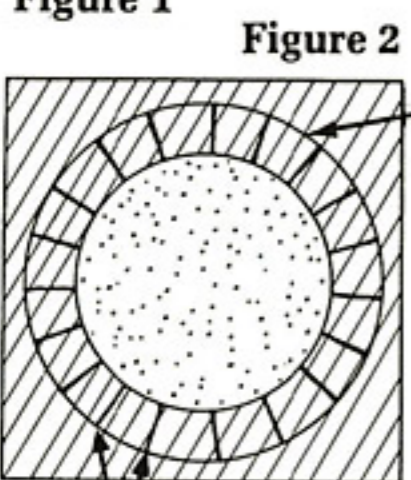

Figure 2

- Brush one side of cardboard with ULTRA-SEAL™ glue/sealer; place glued side of cardboard on wrong side of fabric, following pencilled guideline.

- Trim fabric to 1/2" around cardboard circle. (See Figure #2)
- Clip fabric every 1/2". (See Figure #2)

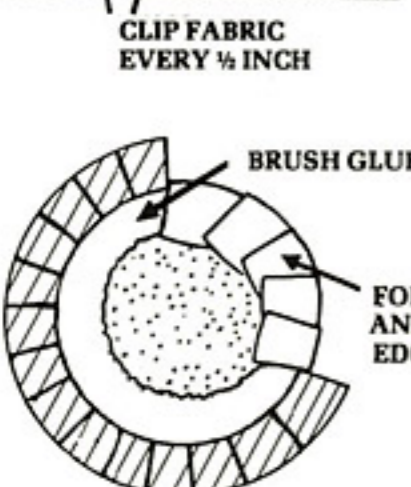

Figure 3

- Brush ULTRA-SEAL™ on outer 1/2" of cardboard; fold clipped edges of fabric over edge of cardboard and press down onto 'glued' cardboard. Repeat around entire circle. (See Figure #3)

- Place this glued fabric disc on a sheet of plastic wrap and weight it down with a heavy book for one hour.
- Apply a thin, even brush coat of ULTRA-SEAL™ on front of fabric disc making sure no portions of fabric or cross-stitch design are left unsealed. Allow to air-dry one hour.
- Apply thin, even brush coat of ULTRA-SEAL™ to the edges and back of the fabric disc. Allow to air-dry at least one hour or until the piece is completely dry.

### INSTRUCTIONS FOR CASTING

#### First Layer

- Support dome mold in an empty glass or paper cup. Make sure the mold is level.
- In graduated mixing cup measure and mix thoroughly 2-1/2 ounces of resin and 10 drops of catalyst. Pour into mold and allow to gel, approximately 20-25 minutes.

#### Second Layer

- In a clean graduated mixing cup, measure and mix thoroughly 1/2 oz. resin and 2 drops' catalyst. Using a dry 1/2" acid tinning brush, brush front of fabric disc with catalyzed resin. Pour remaining resin onto gelled layer. Center fabric disc face down in resin. Press disc gently with stir stick to remove any trapped air bubbles.
- Allow this second layer to firm gel, approximately 20-25 minutes.

#### Third Layer

- In a clean graduated mixing cup, measure and stir thoroughly 1 ounce of resin, 2 to 3 drops of color pigment and 3 drops of catalyst.
- Pour mixture into mold over back of fabric disc. Do not overfill the mold.
- Allow to harden approximately 6-8 hours. When cured the casting will shrink away from the mold. The surface will 'click-hard' when tapped with a stir stick.

### REMOVE CASTING FROM MOLD

- Invert mold, grasp edges, flex and allow the casting to gently drop onto a piece of Mylar™ or waxed paper.
- If slightly tacky, allow to air-dry several days before using.
- To protect furniture you may want to glue a circle of felt onto the back of your "Embroidery" Paperweight.

## 2-LAYER CASTING (BEGINNER)

Have fun customizing gifts and experimenting with different types of letters, emblems or symbols. The size, thickness, and number of letters you use will determine the size poly mold you'll need. As a guide, you can fit up to five 1/2" wide letters into a 2-5/8" long MC-2 Poly Mold. (Larger and smaller molds are available.)

## KEY I.D. (IDENTIFICATION TAG)



### MATERIALS NEEDED

- 1 MC-2 Poly Mold (2-1/4" x 2-5/8" x 1-1/8")
- 1 Oz. Polyester Casting Resin
- Catalyst
- Up to five 1/2" wide acrylic letters (dry alphabet soup letters, enameled initials, etc.)
- 2 Graduated Paper Mixing Cups
- 2 Stir Sticks
- Color Pigment for Polyester Resin
- Acetone or Rubbing Alcohol for clean-up
- Electric Drill and 1/8" drill bit
- Bead-Type Key Chain
- Optional: Resin Craft Surface Coat Spray (high-gloss acrylic sealer).

### INSTRUCTIONS

#### First Layer

- In mixing cup measure and mix thoroughly 1/2-ounce of casting resin and 4 drops of catalyst.
- Pour into poly mold and allow to gel, approximately 20 minutes.
- Place letters face down onto gelled layer. (Note: Letters will be placed right to left and will read backwards when you look down on them.)
- Firmly press letters down with a clean stir stick to prevent the next layer of resin from running under them.

#### Second Layer

- In a clean mixing cup, measure and mix thoroughly 1/2-ounce of casting resin, 2 drops of color pigment, and 3 drops of catalyst.
- Pour mixture over letters and first gelled layer.
- Allow this layer to harden completely before removing from the mold. Edges will shrink from sides of the mold. When tapped with a stir stick, surface will 'click-hard'.

### REMOVE CASTING FROM MOLD

- Invert mold, flex edges, and allow the casting to gently drop onto a piece of Mylar™ or waxed paper.
- Do not handle until completely tack-free.

### FINISHING

- Using your electric drill, slowly drill a hole 1/4" from the left side of cast nameplate.
- To cover any fingerprints or blemishes, you may want to spray your finished casting with a Resin Craft Surface Coat Spray. Allow to dry.
- Thread beaded key chain through drilled hole and add keys!

### 3-LAYER CASTING (BEGINNER)

For a great practical joke, pop this Creepy Crawler along with several real ice cubes into a friend's tall frosty drink. Keep a straight face while waiting for the little critter to be discovered! TIP: Make crystal clear ice cubes from boiled or distilled water . . . or, you can cast clear cubes of resin, using the MC-1 Poly Mold.

## CREEPY CRAWLER COOLER



### MATERIALS NEEDED

- 1 Creepy Crawler (a dried fly, spider, caterpillar, or hard-shelled bug). You can freeze a live bug for several hours to kill it, and then dry it in a silica gel for several days. Silica gel or drying crystals are found in floral departments at craft and hobby stores. Gently brush off any silica particles before embedding. Some plastic bugs can be embedded without distortion from the heat generated during curing of the resin.
- 1 MC-1 Poly Mold (2" x 1-1/2" x 1")
- 2 Oz. Polyester Casting Resin
- Catalyst
- 3 Graduated Paper Mixing Cups
- 3 Stir Sticks
- Acetone or Rubbing Alcohol for clean-up
- Optional: Disposable plastic gloves or tweezers

### INSTRUCTIONS

#### First Layer

- In mixing cup, measure and mix thoroughly 1/2-ounce of resin and 3 drops of catalyst. Pour into mold.
- Allow to gel, approximately 20 to 25 minutes.
- Place dried bug face down on gelled resin. (TIP: To prevent air bubbles, dip bug into your second batch of catalyzed resin before placing on first gelled resin layer.)

#### Second Layer

- In a clean mixing cup, measure and mix thoroughly 1/2-ounce of casting resin and 2 drops of catalyst.
- Pour mixture over first gelled layer and the bug. (Bug may have a tendency to slide or float in this layer. Check casting frequently.)
- Allow resin to gel, approximately 20 minutes.

#### Third Layer

- In a clean mixing cup, measure and mix thoroughly 1 ounce of casting resin and 3 drops of catalyst.
- Pour mixture over the second gelled layer.
- Allow casting to harden thoroughly before removing from the mold.

### REMOVE CASTING FROM MOLD

- Edges of the hardened (cured) casting will shrink away from sides of mold. When tapped with a stir stick the surface of the casting will 'click-hard'. Invert mold, flex edges, and allow the cast cube to gently drop onto a sheet of Mylar™ or plastic wrap.
- To avoid fingerprints, do not handle the cast piece until it is completely dry.

### 3-LAYER CASTING (BEGINNER)

Our shell night light is a glowing reminder of lazy days spent at the seashore gathering treasures. You may want to include a 'specimen' such as a tiny sea horse, blowfish, or starfish, available at a shell or hobby shop.

## NIGHTY NIGHT-LIGHT



### MATERIALS NEEDED

- 1 MC-1 Poly Mold for Casting Resin (2" x 1-1/2" x 1" deep)
- 2 Oz. Polyester Casting Resin  
Catalyst
- 3 Graduated Paper Mixing Cups
- 3 Stir Sticks
- 3-4 Clean, dry, tiny shells
- 1 General Electric Guide Light™—available at most hardware stores

### INSTRUCTIONS

#### First Layer

- In paper mixing cup measure and mix thoroughly 1/2 ounce resin and 3 drops of catalyst.
- Pour into mold.
- Allow this layer to gel, approximately 20 to 25 minutes.

#### Second Layer

- Place shells face down on gelled surface.
- In a clean mixing cup, measure and mix thoroughly 1/2 ounce resin and 2 drops of catalyst.
- Pour over shells and allow to gel, approximately 20 minutes.
- Place 'Guide Light'™ onto gelled surface (or on shells if shells rise above the gelled surface). Make sure the 'Guide Light' is level and that the metal prongs will not be covered with resin. If necessary, use a piece of masking tape over the light and edges of mold to hold the light in place.

#### Third Layer

- In a clean mixing cup, measure and mix thoroughly 1 ounce of resin and 3 drops of catalyst.
- Pour into mold, being careful not to over-fill the mold or pour any resin on the metal prongs of the 'Guide Light'™.

### REMOVE CASTING FROM MOLD

- Allow the casting to dry completely before removing from mold (4 to 24 hours). When cured, the casting will shrink away from the edges of the mold. The surface will 'click-hard' when tapped with a stir stick.
- Invert mold, grasp edges, flex and allow the casting to gently drop onto a piece of Mylar™ or waxed paper.
- If the night light is slightly tacky, allow to air-dry up to several days before handling or using.

## SINGLE LAYER CASTING (BEGINNER)

Kids love to help with this holiday project! As a variation you might try adding two drops of red or green transparent dye for polyester resin to each ounce of resin in addition to the catalyst. The finished ornament will then have a deep colored design and a pastel frosted background.

# FROSTED ORNAMENTS

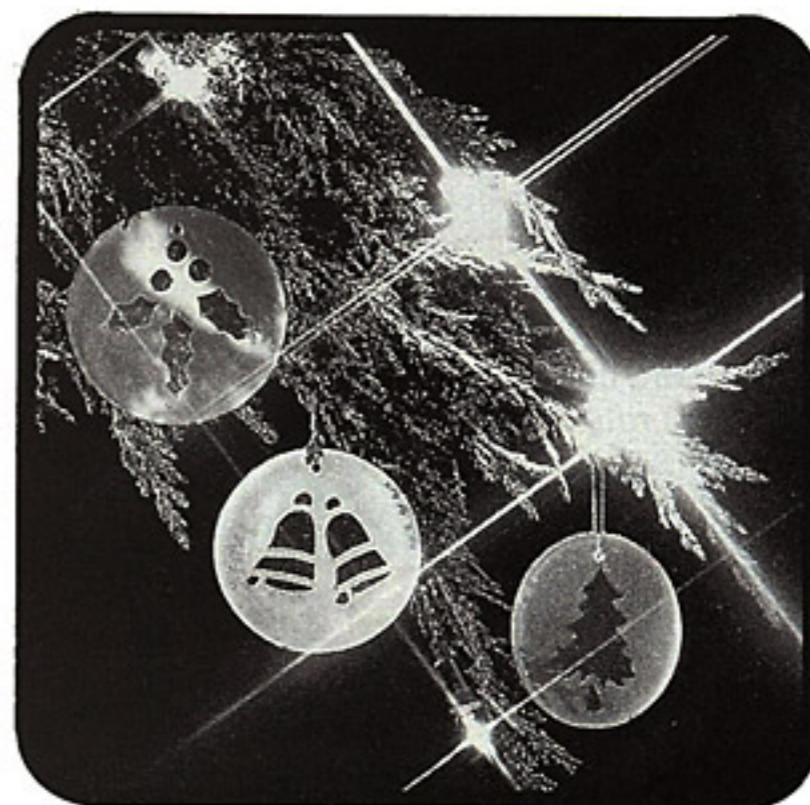

## MATERIALS NEEDED TO MAKE SIX ORNAMENTS

- 3 MC-1 Poly Molds (2" x 1-1/2" x 1")
- 3 MC-3 Poly Molds (2-3/8" diameter x 1-1/8")
- 3 Oz. Casting Resin
- Catalyst
- 1 Stir Stick
- 1 Graduated Paper Mixing Cup
- 1 Set Pre-Cut Adhesive Vinyl Stencils . . . such as Quick Silver Super Stencils™ 1-1/2" Holiday Designs
- 1 X-Acto™ Knife
- 1 6-Oz. Can Translucent Frost Spray Finish—such as Satin Mist™
- Transparent Nylon Thread or Gold or Silver Cord
- Electric Drill and 1/16" drill bit
- Optional: Tiny Gold or Silver Braid
- Epoxy Glue or Bond Cement

## INSTRUCTIONS

### First Layer

- In a mixing cup measure and mix thoroughly 3 ounces of casting resin and 45 drops of catalyst. (Note: The high amount of catalyst called for in this project is necessary due to the thinness of the single-layer pour. Undercatalyzing will make it difficult if not impossible to remove the casting from the mold.)
- Pour 1/2-ounce of resin mixture into each of the six molds.
- Allow castings to harden completely before unmolding. (4-24 hours)

## REMOVE CASTING FROM MOLD

- When cured, casting will shrink away from the edges of the mold. The surface will 'click-hard' when tapped with a stir stick.
- Invert mold, grasp edges, flex and allow the casting to gently drop onto a piece of Mylar™ or waxed paper.
- Do not handle cast pieces until they are completely dried. This may take several days.

## FINISHING

- Place a disc in a vise or flat on a scrap piece of wood.
- Slowly drill a hole through cast disc, 1/4" down from top of ornament. Repeat for other discs.
- Apply a 'pressure-sensitive' stencil to the back of each plastic ornament. Carefully peel off unwanted portions of stencil with an X-Acto™ knife.
- Place ornaments, stencil side up, on a sheet of plastic wrap.

- Spray stencil side of ornaments with frosting, following directions on can label. (Repeat with additional coats if desired.)
- Allow to dry thoroughly before carefully peeling away stencils with the aid of an X-Acto™ Knife.
- If desired, use epoxy glue or bond cement to attach gold or silver braid trim.
- For each ornament cut an 8" length of transparent nylon thread or cord. Thread through hole in ornament and tie ends in square knot.

*Other Ideas:* Frosted ornaments can be used to make a holiday wind chime. Or, if you can locate initial stencils, spell out "MERRY CHRISTMAS" and string to use with evergreen boughs over your doorway or mantel.

## 4-LAYER CASTING (INTERMEDIATE)

This practical project makes a perfect gift for dad or a favorite 'paper shuffler'. Here I show an old, non-working watch that has been taken apart and the pieces embedded in layers of resin to give a dimensional or floating effect.

You might choose to layer coins (a trip to a foreign bank, where the exchange rate is in your favor, will produce a handful of unusual coins for a dollar or two).

# 'TIMELESS' PEN HOLDER



A trip to a second hand store or garage sale should produce some real 'finds'. Remember... embedments must be dry and free of grease and oil for the resin to cure properly around them. Do not embed anything really valuable because it will be next to impossible to 'uncast' your treasures.

## MATERIALS NEEDED

- 1 MC-7 Poly Mold (3" x 5" x 1-1/16")
- 8 Oz. Polyester Casting Resin
- Catalyst
- 4 Graduated Paper Mixing Cups
- 4 Stir Sticks
- Old watch parts, assorted coins, etc.
- Pen & Funnel (available at craft stores)
- White or Black Color Pigment for Polyester Resin
- Epoxy Glue or Bond Cement
- Acetone or Rubbing Alcohol for clean-up
- Optional: Self-adhesive Felt Dots (available at craft or variety stores)

## INSTRUCTIONS

### First Layer

- In a mixing cup measure and mix thoroughly 2 ounces' casting resin and 10 drops of catalyst.
- Pour into mold and allow to gel, approximately 20 to 25 minutes.

### Second Layer

- In a clean mixing cup, measure and mix thoroughly 2 ounces of casting resin and 8 drops of catalyst.
- Pour approximately 1 ounce of this mixture onto the gelled layer.
- Place one-half of the watch parts (smaller pieces) into the resin you've just poured, pressing the pieces gently with your stir stick to force trapped air bubbles to rise.
- Pour remaining 1 ounce of catalyzed resin over the watch parts.
- Allow this layer to gel, approximately 20 minutes.

### Third Layer

- In a clean mixing cup, measure and mix thoroughly 2 ounces of resin and 6 drops of catalyst.
- Pour 1 ounce of this mixture onto the gelled layer.
- Place the remaining watch parts into the resin you've just poured, pressing pieces gently with your stir stick to force any trapped air bubbles to rise.
- Pour the remaining 1 ounce of catalyzed resin over the watch parts.
- Allow this layer to firm gel, approximately 20 minutes.

### Fourth and Final Layer

- In a clean mixing cup, measure and mix thoroughly 2 ounces resin, 6 drops white or black color pigment, and 4 drops of catalyst.
- Pour onto gelled layer.
- Allow to harden completely before removing from the mold. (4-24 hours)

## REMOVE FROM MOLD

- When cured, your casting will shrink away from the edges of the mold. When tapped with a stir stick, the surface will 'click hard'.
- Invert mold, grasp edges, flex and allow the casting to gently drop onto a piece of Mylar™ or waxed paper.

## FINISHING

- Mix a small batch of epoxy glue according to manufacturer's directions. Apply the glue to the underside of the funnel and attach to the paperweight. Allow to dry thoroughly before using.

(Note: Pen and Funnel sets may also come with a machine screw. Optional method of mounting the funnel is to drill a 1/8" hole through the casting and place the proper length screw from the bottom of the casting).

- To protect furniture, place four self-adhesive felt dots to the base of casting.

## SINGLE LAYER CASTING (BEGINNER)

You can personalize this project for just about anyone to let them know you think they're the greatest!

Our local trophy shop was the source for the plastic loving cup which cost under \$1.00. A garage sale might produce some old trophy parts which you could use for your special project. Our base is made of marbled casting resin and the 'engraved plate' we had made.

# "WORLD'S GREATEST" TROPHY!



## MATERIALS NEEDED

- 1 MC-6 Plastic Poly Mold (3" x 3" x 1-1/16")
- 5 Oz. Polyester Casting Resin
- Catalyst
- 1 Graduated Paper Mixing Cup
- 1 Stir Stick
- White and Black Color Pigment for Polyester Resin
- Toothpick
- Acetone or Rubbing Alcohol for clean-up
- Engraved plate or peel-and-press stickers or rub-on lettering
- Optional: Resin Craft Surface Coat (an acrylic spray sealer)
- Epoxy Glue or Bond Cement
- Trophy or piece of statuary

## INSTRUCTIONS

### Single Layer Casting

- In a mixing cup measure and mix thoroughly 5 ounces of casting resin, 10 drops of white color pigment (an amount about the size of a pea), and 20 drops of catalyst.
- Pour into mold.
- Squeeze a drop of black color pigment onto a piece of plastic wrap.
- Using a toothpick, pick up a small amount of black pigment and carefully swirl through the poured resin to obtain a marbled effect. Repeat with additional black pigment if desired.  
(Multiple colors, or another color, may be used).

## REMOVE CASTING FROM MOLD

- Allow the casting to harden completely before removing from the mold. To unmold; invert mold, grasp edges, flex and allow the casting to gently drop onto a piece of Mylar™ or waxed paper.

## FINISHING

- Mix a small batch of epoxy glue according to the manufacturer's directions.
- With your stir stick, spread small amount of epoxy on the back of the engraved plate. Attach the plate to base of casting.
- Spread a small amount of epoxy to the underside of your trophy. Attach to the top of casting.
- Allow the epoxy to dry thoroughly before using your trophy.

## ALTERNATIVES AND OTHER IDEAS

An alternative for lettering would be peel-and-press stickers or rub-on lettering which are available in a wide variety of sizes and styles. If using rub-on lettering, spray your finished letter base (before mounting the trophy) with Resin Craft Surface Coat Spray (a clear acrylic sealer). This will prevent the letters from peeling off later.

Here are some other ideas for trophies: For your favorite golfer make a clear base with golf tees embedded and a golf ball glued to the top. Title your creation, "World's Greatest Duffer". For the family tennis star, glue a racket-holding-"Snoopy" statue on the base you've made and rub on the letters "ACE"!

## 4-LAYER CASTING (INTERMEDIATE)

Practical and pretty, this useful project makes a lovely gift and can be customized to compliment any kitchen decor by using different backgrounds. Besides dried peas, beans or spices, you can embed colorful straw flowers or pressed weeds and leaves. If you want to use leftover kitchen wallpaper or curtain fabric for a background, glue to a piece of cardboard the same size as your mold. Seal front and back with white glue and allow to completely dry before embedding.

# “EGG-TIMER” RECIPE CARD HOLDER

## MATERIALS NEEDED

- 1 MC-7 Poly Mold (3" x 5" x 1-1/16")
- 8 Oz. Polyester Casting Resin  
Catalyst
- 4 Graduated Paper Mixing Cups
- 4 Stir Sticks
- 1 Glass Egg Timer (available from variety or craft store. If timer comes in a holder, remove the holder before embedding. Clean timer with soap and water, and dry with soft cloth before embedding.)  
Dry Spaghetti  
Dried Peas, Beans, Alphabet Macaroni, Seeds, Spices and/or Dried Flowers. (Do not use cloves as they are quite oily)  
Tweezers  
Acetone or Rubbing Alcohol for clean-up
- 2 Paper Clips  
Epoxy Glue or Bond Cement

## INSTRUCTIONS

### First Layer

- In a mixing cup measure and mix thoroughly 2 ounces of casting resin and 8 drops of catalyst.
- Pour into mold.
- Allow to gel, 20 to 25 minutes.

### Second Layer

- Place egg timer on gelled surface.
- In a clean mixing cup, measure and mix thoroughly 1 ounce of casting resin and 3 drops of catalyst.
- Pour around egg timer onto gelled first layer.
- Allow second layer to gel, 20 to 25 minutes. This pour will 'anchor' the egg timer.
- Check periodically to center the egg timer.

### Third Layer

- In a clean mixing cup, measure and mix thoroughly 3 ounces of resin and 6 drops of catalyst. Pour over egg timer and second gelled layer.
- Allow third layer to gel, approximately 20 minutes. While waiting for this layer to gel, prepare the dried spaghetti according to the following directions:

### Fourth Layer

- Using dry spaghetti, cut or break off lengths to form a frame for dried peas, beans, spices. (See Figures A & B for 'framing' possibilities. Hollow lines inside mold represent spaghetti.)

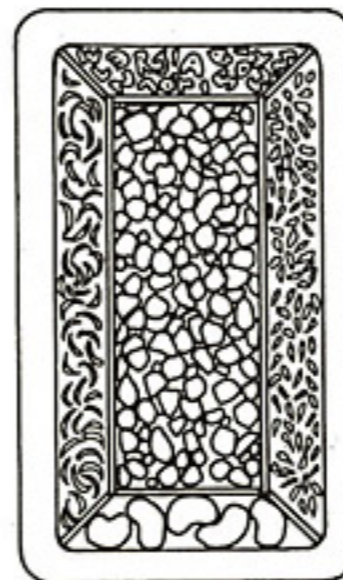

Figure A

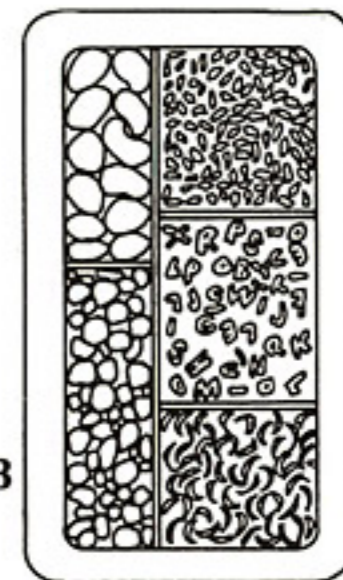

Figure B

- Using tweezers, place lengths of spaghetti on the gelled resin according to the pattern you've selected. Fill each compartment with a different dry food or spice.
- In a clean mixing cup measure and mix thoroughly 2 ounces of casting resin and 2 drops of catalyst.
- Carefully pour over dried material. Do not overfill the mold.

## REMOVE CASTING FROM MOLD

- Allow casting to harden completely before removing from the mold (4 to 24 hours). When cured casting will shrink away from the edges of the mold. The surface will 'click-hard' when tapped with a stir stick.
- Invert mold, grasp edges, flex and allow the casting to gently drop onto a piece of Mylar™ or plastic wrap. If finished piece is still slightly tacky when removed from the mold, allow to air-dry on Mylar™ or plastic wrap another 24 to 48 hours before gluing on paper clips.

## FINISHING

- Pry open two paper clips very slightly, place glue on bottom third of each clip. Place a clip at each end of the back of the casting. (See Figure C)
- The clips should not show from the front.
- When the glue is dry, either clip will hold a recipe file card out of the way of food preparation!



Figure C



## SINGLE LAYER CASTING (INTERMEDIATE)

Half the fun of making this musical project is the collecting and pressing of Mother Nature's miracles! Your craft or hobby shop will have pressed butterflies in case you don't feel like romping through meadows with a butterfly net!

To collect flowers, take an old heavy book along to the woods, fields, or railroad tracks. Each season will yield its own delicate wild-flowers and lacy greenery. Look for flowers, leaves and weeds that are tiny and will press flat. Be aware of flower centers which are too thick. These centers can be gently cut off from the back side to make them more pressable. You'll have to experiment a little to find flowers that will keep their color through pressing and then casting in resin. Place flowers and leaves in your book as you pick them to prevent wilting or curling. When you get home, weight down your 'pressing' book with several additional heavy books and allow to dry undisturbed for one to three weeks.

# BUTTERFLY WIND CHIME

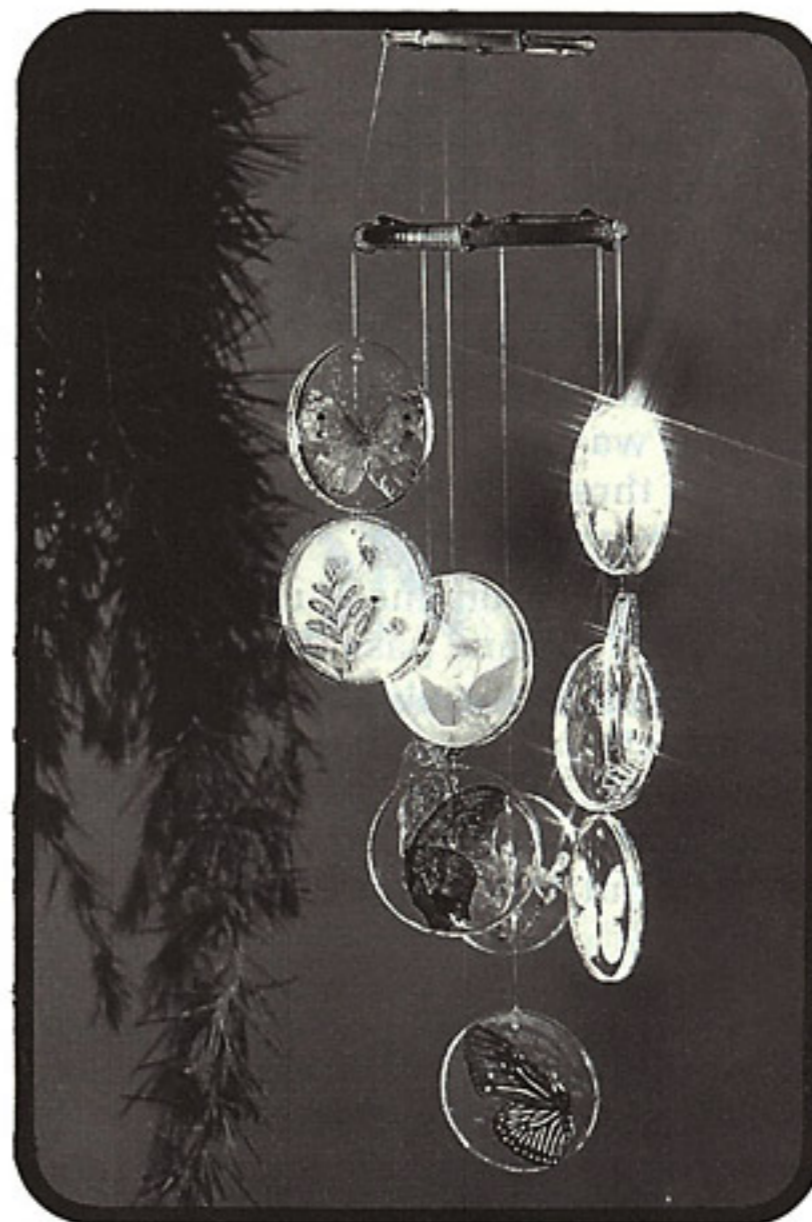

## MATERIALS NEEDED TO MAKE TWELVE DISCS

3 to 6 MC-3 Poly Molds (2-3/8" diameter x 1-1/8") (You'll need to pour in several sessions 12 to 24 hours apart.)

6 Oz. Polyester Casting Resin

Catalyst: 15 drops per ounce of resin

1 Graduated Paper Mixing Cup and Stir Stick for each pour you will be making.

6 Pressed Butterflies

Assortment of Pressed Flowers and Leaves

Tweezers

Acetone or Rubbing Alcohol for clean-up

Electric Drill with 1/16" drill bit

Transparent Nylon Thread or Fishing Line

1 3" Bamboo Ring

1 4" Bamboo Ring

1 1" Curtain Ring (brass or plastic)

## INSTRUCTIONS

### Making Butterfly and Flower Discs

- On a piece of paper, trim and arrange flowers the way you will want them to look in the mold.
- In paper mixing cup, measure 1/2-ounce resin for each mold you will be pouring and 15 drops of catalyst for each ounce of resin. (This high amount of catalyst is needed to produce a hard cure in a very thin single pour.)
- Thoroughly mix resin and catalyst and pour 1/2-ounce into each mold (about 1/8" in thickness).
- **DO NOT WAIT FOR RESIN TO GEL.** Using tweezers, immediately place flowers or butterflies face down onto resin. Using your stir stick, very gently press flowers or butterflies down into the resin. Work from the center outward, gently pressing air bubbles out from under the flowers and butterflies. Clean tweezers immediately with acetone or rubbing alcohol.
- Allow castings to cure 12 to 24 hours before turning out onto MYLAR™ or plastic wrap. When cured casting will shrink away from the edges of the molds. The surface will 'click-hard' when tapped with a stir stick. If still tacky, allow to air-dry another 24 hours before drilling holes.

- Place disc in vise or flat on a block of scrap wood. Using 1/16" drill bit, slowly drill a hole through each disc 1/4" down from top of disc. Repeat for remaining discs.
- Using the 1/16" bit, drill six holes evenly spaced through the 3" bamboo ring. (See Figure #1).
- Drill three holes, evenly spaced, through the 4" bamboo ring. (See Figure #2)
- Cut three 60" lengths of nylon transparent thread.
- Attach curtain ring to a hook on the wall or a door knob to make assembling easier.
- Pick up three ends of thread and pass through the curtain ring. (See Figure #3)

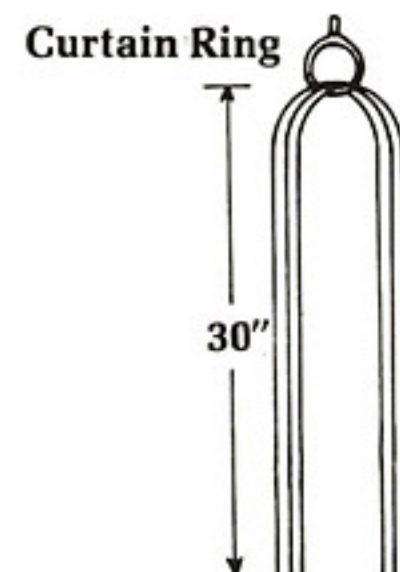
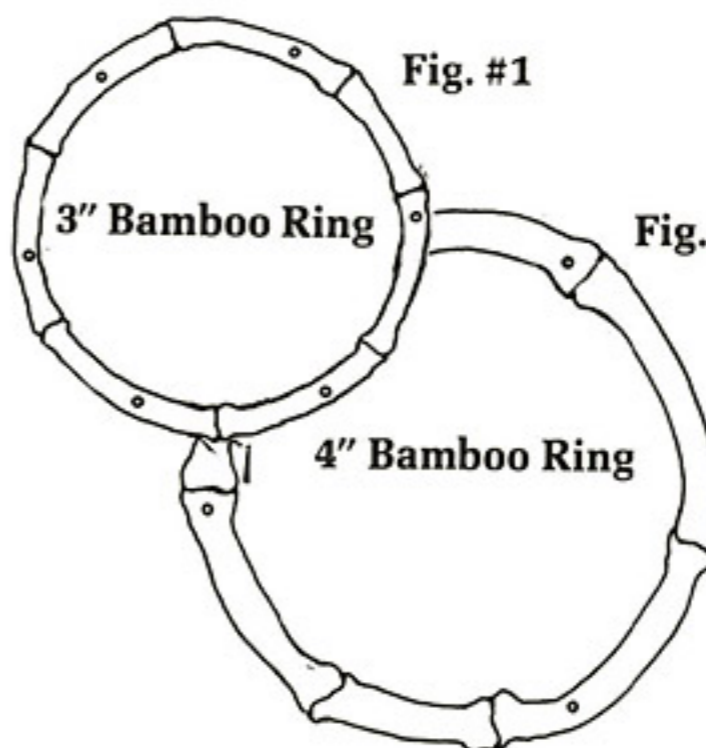

Fig. #3

# NOTES

- Match up the other three ends and tie a square knot to hold threads in place. (See Figure #4)
- Take one strand and pass through a hole in the 3" bamboo ring. Adjust the length of this strand to about 8" between the curtain ring and bamboo ring. Make an overhand knot to keep the ring from sliding on the thread. (See Figure #5)
- Repeat the same process with the other five strands, working your way around the ring. Take care to keep the lengths of thread between the curtain ring and bamboo ring even.
- Allowing a 6" drop-from the 3" ring to the 4" ring-take one strand of thread and pass through a hole in the 4" ring. Tie an overhand knot. Skip a thread and repeat with the next strand. (See Figure #6) Skip another thread and repeat with the next strand. Bring the remaining 3 loose strands to the inside of the rings before adding butterfly discs.



Fig. #4



Fig. #5

8"



Fig. #6

6"

## ASSEMBLING WIND CHIME

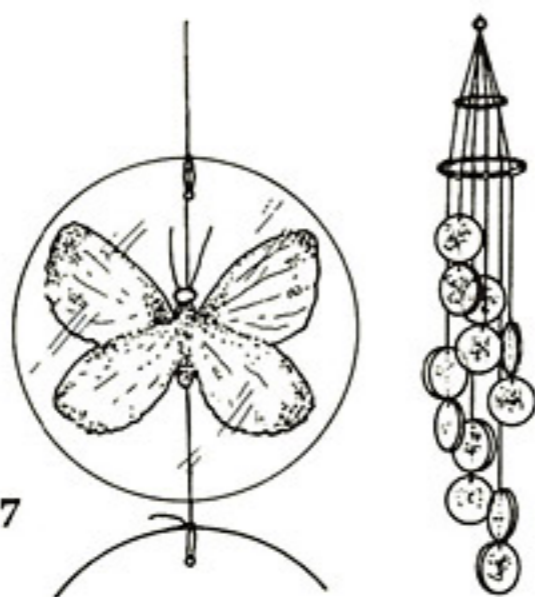

Fig. #7

- Starting with one strand, pass thread through hole in a flower or butterfly disc. Tie a double knot to secure. Pass the end of this same thread through a second disc and space so the two discs barely touch. Tie a double knot to secure and clip off surplus thread. (See Figure #7)
- Repeat above with next thread and add two discs.
- Work your way around the rings until two discs have been added to each thread in a spiral fashion.

## RESIN CASTING GLOSSARY

**ACETONE** — A solvent used to clean up polyester casting resin while a liquid. Rubbing alcohol is also suitable for cleanup.

**CASTING** — Hardened or cured project made with casting resin. Also, the process of creating a project with polyester casting resin.

**CASTING RESIN** — A water-clear polyester resin noted for its clarity, sparkle and brilliance. Designed to be used by handcrafters for embedding objects, specimens, etc.

**CATALYST** — A chemical agent added to casting resin to convert the resin from a liquid to a solid. (Catalyst is sometimes called 'hardener'.)

**COLORANTS** — Dyes and pigments developed primarily for use with polyester resin. Opaque pigments produce a solid color. Transparent dyes produce a 'see-through' color.

**CURE** — The hardening process that casting resin goes through after catalyst has been added. Stages of this process go from a liquid to a 'soft gel' at about 20 minutes to a 'click-hard' in 1 to 24 hours.

**EMBEDMENTS** — Objects to be encased or suspended in casting resin. Embedments must be dry, wax-free and grease-free.

**EXOTHERM** — The internal heat created as catalyzed resin goes through the hardening, or curing process.

**FRACTURE** — A split or crack in a casting caused by over-catalyzing.

**GEL** — A stage of curing when the resin appears like 'set' gelatin. At this point the weight of embedments can be supported by the 'gelled' layer of resin.

### **GRADUATED or CALIBRATED MEASURING/MIXING CUPS:**

Cups with markings indicating number of ounces or pints, necessary for accurate measuring of polyester resin. Suitable cups would be made of Pyrex™, polyethylene, or disposable paper cups with a plastic lining.

**LATEX MOLD MATERIAL** — In liquid form natural latex can be brushed in layers on a sculptured form or master. The resulting flexible glove mold can be filled with catalyzed polyester resin, plaster, or candle wax to produce an exact copy of the original piece.

### **CASTIN' CRAFT PRODUCTS**

- WATER CLEAR POLYESTER CASTING RESIN
- CATALYST FOR CASTING RESIN
- GRADUATED MIXING CUPS & STIR STICKS
- TRANSPARENT DYES
- OPAQUE PIGMENTS
- REUSABLE POLY MOLDS IN 8 SIZES

**MOLD** — A container in which resin is cast. Mold materials for casting resin include: Oven-safe glass, metal, polypropylene and polyethylene, latex, silicone R.T.V., ceramic, polyurethane elastomers, and flexible vinyl plastisol.

**MOLD RELEASE** — A water-soluble liquid or paste applied to inside of molds to ease removal of castings.

**MULTIPLE POUR** — A casting technique using several layers or separate pours of resin. Each pour allows the addition of embedments. Many layers of embedments produce a floating or dimensional appearance.

**MYLAR™** — Trademark of DuPont for a polyester film or sheeting. Resin casts will not stick to MYLAR™ nor will the MYLAR™ leave marks on drying castings.

**POLYPROPYLENE & POLYETHYLENE MOLDS** — Low-cost plastic molds which can be used repeatedly with casting resin and which require no mold release.

**POT LIFE** — See 'Working Time'.

**RESIN CRAFT SURFACE COAT\*** — A multi-use clear acrylic, high-gloss resin spray used to cover fingerprints and imperfections on resin castings.

**SINGLE POUR** — A casting where only one layer is made.

**STYRENE** — An aromatic organic component of polyester resin. The odor associated with casting resin is the styrene.

**SURFACE CURING AGENT** — An additive used in the final pour layer in addition to catalyst and casting resin to produce a hard tack-free surface.

**TACK-FREE** — A surface which may be touched without sticking or leaving fingerprints. A 'tacky' surface would be like touching the sticky side of cellophane tape.

**ULTRA-SEAL™** — White vinyl resin glue and sealer. Brushed on fabric, photographs or wood, ULTRA-SEAL prevents 'wet-out'. Four parts of white glue to one part of water may be substituted.

**WORKING TIME** — The amount of time between the addition of catalyst to casting resin and 'set-up' of the resin; generally 15 to 25 minutes.

- ULTRA-SEAL™ — VINYL RESIN GLUE AND SEALER
- LATEX MOLD BUILDER
- RESIN CRAFT SURFACE COAT SPRAY
- SURFACE CURING AGENT
- PVA MOLD RELEASE

# castin'craft

**NOW—THE MAGIC OF RESIN CASTING  
AS EASY AS CREATE...AND CAST!**

**a book full of fun,  
step-by-step projects.**



FROSTED  
ORNAMENT

TIMER &  
RECIPE HOLDER

WORLD'S  
GREATEST

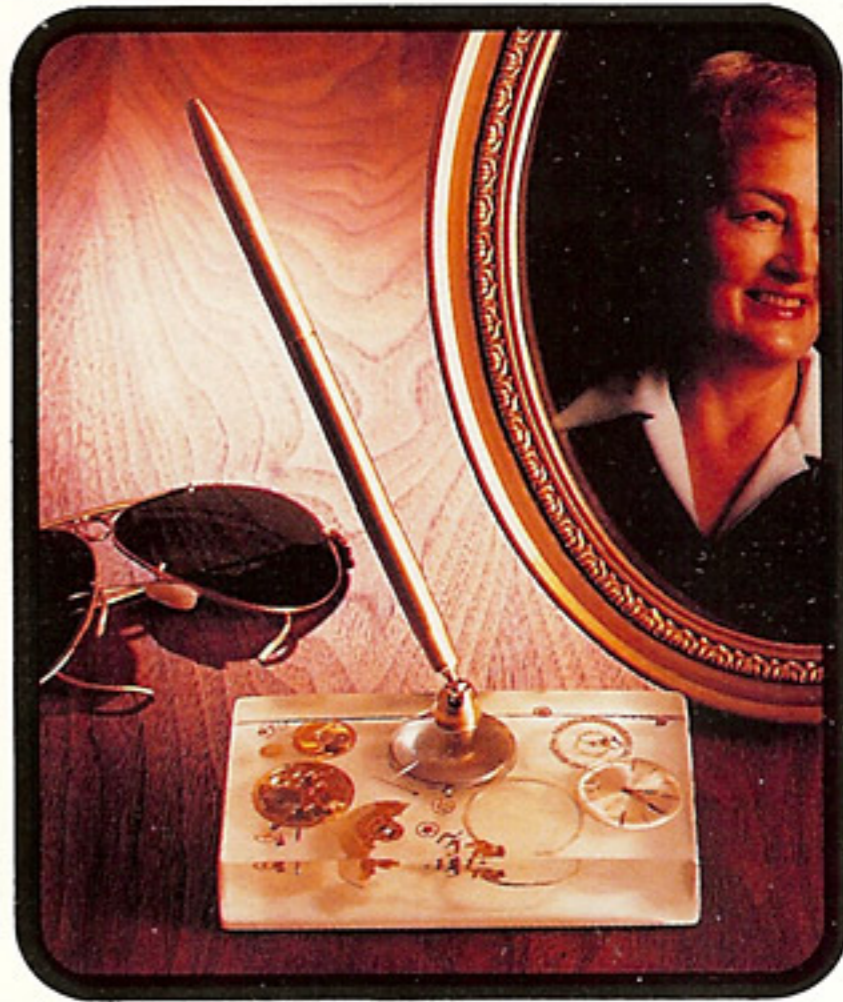

TIMELESS  
PEN HOLDER



KEY I.D.s

NIGHTY-NIGHT LIGHT

